



# Energy

## Emergency Support Function (ESF) 12

### Coordinating:

Department of Commerce Energy Division, State Energy Office

### Primaries:

Department of Commerce Energy Division, State Energy Office

### Supporting:

Utilities & Transportation Commission (UTC)

Department of Enterprise Services (DES)

## Purpose

This document is a supporting annex of the Washington State Comprehensive Emergency Management Plan (CEMP) and operates in conjunction with all its annexes. ESF 12 provides for the effective use of available electric power, natural gas and petroleum products required to meet essential needs and to facilitate restoration of energy systems affected by an emergency or disaster by orchestrating the Energy stakeholders, activities, and services provided under the primary Core Capability of Infrastructure Systems. Additionally, ESF 12 supports the following Core Capabilities based on intersecting activities with other ESFs: Operational Coordination, Logistics & Supply Chain Management, and Situational Assessment.

### Primary Response Core Capability

<b>Infrastructure Systems</b>	Stabilize critical infrastructure functions, minimize health and safety threats, and efficiently restore and revitalize systems and services to support a viable, resilient community.
-------------------------------	--

### Support Response Core Capabilities

<b>Operational Coordination</b>	Establish and maintain a unified and coordinated operational structure and process that appropriately integrates all critical stakeholders and supports the execution of Core Capabilities.
<b>Logistics &amp; Supply Chain Management</b>	Deliver essential commodities, equipment, and services in support of impacted communities and survivors, to include emergency power and fuel support, as well as the coordination of access to community staples. Synchronize logistics capabilities and enable the restoration of impacted supply chains.
<b>Situational Assessment</b>	Provide all decision makers with decision-relevant information regarding the nature and extent of the hazard, any cascading effects, and the status of the response.

## Authorities and Policies

### Presidential Policy Directives (PPDs)

#### PPD-21

*Sets national policy on critical infrastructure security and resilience. The goal of the directive is to foster greater cooperation between public and private entities, reduce*

*vulnerabilities, identify and disrupt threats, minimize consequences, and hasten response and recovery efforts related to critical infrastructure.*

**PPD-7**

*Establishes a national policy for Federal departments and agencies to identify and prioritize critical infrastructure and to protect them from terrorist attack.*

**Revised Code of Washington (RCW):**

**39.26.130, Public Contracts and Indebtedness, Emergency Purchases.**

*Outlines emergency purchasing policies and procedures for state agencies.*

**43.19.450, Department of Enterprise Services, Engineering and Architecture.**

*Defines “state facilities” and identifies designee for contract of architectural, engineering or related services for major repair to existing state facilities.*

**43.21F, State Energy Office**

*Defines the roles and responsibilities for the State Energy Office, including their role in implementing policy during energy emergencies.*

**43.21G, Energy Supply Emergencies, Alerts**

*Relevant to Energy, establishes necessary emergency powers for the governor and defines the situations under which such powers are to be exercised.*

**43.155.065, Emergency public works projects.**

*Establishes low-interest or interest-free loans for emergency public works projects.*

**Washington Advisory Code (WAC):**

**194, Commerce, Department of (Energy)**

*Provides guidance from Commerce on Energy issues including Emergency Petroleum Allocation Act rules and WA state curtailment plan for electric energy*

**Situation Overview**

ESF-12 addresses significant disruptions in electrical, natural gas, and petroleum supplies caused for any reason. Energy disruptions in Washington are most likely to be caused by windstorms, earthquakes, and cybersecurity-attack, though could be caused by work stoppage, wildfire, tsunami, lahar, or other natural or man-made disaster. The priority is to coordinate an energy supply disruption impacting the state of Washington to reduce hardship and maintain the general welfare for the population of Washington.

The majority of energy generation in Washington is produced via hydro power (dams) located across Washington, Oregon and Idaho. A minority, but critical element of additional power is

produced by coal and natural gas facilities with some located as far away as Wyoming. Therefore, losses associated with transmission capability can be as impactful as interruptions of generation.

Electrical outages impact the state's electrical vehicle fleets including cars, buses, and ferries. Gas stations use electricity to pump their gas and accept payment. Fuel access may become a cascading impact of electrical outages even with the use of short term generators, since generators require a constant supply of fuel.

Petroleum and natural gas supply chains involve multiple private and regulated entities spanning from Alaska to Montana, Canada to California. Western Washington is supplied via the Olympic Pipeline which travels from Alaska, through Canada, and along the I-5 corridor down to Oregon. It is susceptible to a catastrophic, Cascadia-type event, as well as to cyber-attack, and supply chain disruption. Eastern Washington is supplied by a separate supply chain via Idaho, Montana, and Utah.

In the event of a western Washington earthquake event, it is anticipated eastern Washington will support and be engaged with emergency fuel supply requirements.

Oregon relies on Washington to supply a majority of its petroleum product. Therefore ESF 12 is undertaking coordination with Oregon's energy office to de-conflict our plans to provide for a smooth distribution of fuel.

Activities within the scope of this plan are designed to support the target set for the Infrastructure Systems Core Capability, specifically relating to energy infrastructure. The activities and responsibilities contained within this plan relate to the jurisdictional responsibilities of the state of Washington and may not reflect all energy sector actions at different jurisdictional levels. This Annex assumes that the public utility restoration targets will be represented in the local jurisdiction ESF 12 Annexes.

## **Concept of Operations**

ESF 12 facilitates the reestablishment of damaged energy systems and components. Functions include but are not limited to:

- Establish situational awareness for the status of energy systems statewide. This situational awareness should be initially built using the Essential Elements of Information (EEl)s and the process for collection, analysis and dissemination of information is described in the EEl section of this annex;
- Energy infrastructure assessment, repair, and reestablishment;
- Energy industry utilities coordination; and
- Energy forecast.

Energy, utility and petroleum distribution systems will continue to provide services through their normal means, i.e., markets and contracts, during a disaster to the maximum extent possible. Energy, utility and petroleum information will be furnished during emergencies to government officials at all levels to inform the public on the proper use of services. Energy, utility and petroleum companies will compile damage assessment reports and transmit them to the ESF 12. ESF 12 planning assumptions include data evaluation for situation reports and analysis to the State Emergency Operation Center (SEOC) and key government officials on a scheduled, routine basis. ESF 12 will identify problems and make recommendations as necessary for state actions to reduce energy demand, increase energy supplies, allocate and distribute energy resources, and alleviate hardships caused by adverse energy conditions, and carry out interagency agreements and gubernatorial directives.

This ESF is concerned with executing critical tasks that support the response mission area of the following core capabilities: Infrastructure Systems, Operational Coordination, Logistics & Supply Chain Management, and Situational Assessment. The agency responsibilities associated with executing these critical tasks are listed out in the responsibilities section of this document.

<b>Infrastructure Systems</b>	
<b>Critical Task I.D.</b>	<b>Critical Task Description</b>
<b>1</b>	Decrease and stabilize immediate infrastructure threats to the affected population, to include survivors in the heavily damaged zone, nearby communities that may be affected by cascading effects, and mass care support facilities and evacuation processing centers with a focus on life-sustainment and congregate care services.
<b>2</b>	Re-establish critical infrastructure within the affected areas to support ongoing emergency response operations, life sustainment, community functionality, and a transition to recovery.
<b>4</b>	Formalize partnerships with governmental and private sector cyber incident or emergency response teams to accept, triage, and collaboratively respond to cascading impacts in an efficient manner.

<b>Operational Coordination</b>	
<b>Critical Task I.D.</b>	<b>Critical Task Description</b>
<b>1</b>	Mobilize all critical resources and establish command, control, and coordination structures within the affected community, in other coordinating structures within the affected community, in other coordinating bodies in surrounding communities, and across the Nation, and maintains needed throughout the duration of an incident.

Operational Coordination	
Critical Task I.D.	Critical Task Description
2	Enhance and maintain command, control, and coordination structures consistent with the National Incident Management System (NIMS) to meet basic human needs, stabilize the incident, and transition to recovery.

Logistics & Supply Chain Management	
Critical Task I.D.	Critical Task Description
1	Mobilize and deliver governmental, nongovernmental, and private sector resources to save lives, sustain lives, meet basic human needs, stabilize the incident, and transition to recovery, to include moving and delivering resources and services to meet the needs of disaster survivors.
2	Enhance public and private resource and services support for an affected area.

Situational Assessment	
Critical Task I.D.	Critical Task Description
1	Deliver information sufficient to inform decision making regarding immediate lifesaving and life-sustaining activities, and engage governmental, private, and civic sector resources within and outside of the affected area to meet basic human needs and stabilize the incident.
2	Deliver enhanced information to reinforce ongoing lifesaving and life-sustaining activities, and engage governmental, private, and civic sector resources within and outside of the affected area to meet basic human needs, stabilize the incident, and transition to recovery.

### **Whole Community Involvement**

ESF 12 involvement includes whole community engagement response within the SEOC. This includes coordinating with organizations and individuals relevant to the Critical Tasks listed above. Within government response structures, this involves coordinating horizontally with relevant state agencies through the SEOC structures and vertically to federal and local partners. Actions and priorities will be coordinated with private sector, non-governmental, and other organizations that have ownership or input into energy response activities.

ESF 15 (Public Information) should be notified of information to be made available for public consumption and provided with details to ensure messaging reaches the whole community.

Energy-specific partners to involve include:

- Electric generators, electric utilities, and ancillary service providers
- Natural gas suppliers, transporters, handlers, and local distribution companies

- Oil transporters and refiners, and petroleum product transporters, distributors and marketers (wholesale and retail)
- British Columbia, Canada’s energy and energy security ministries and other foreign energy entities when necessary
- National Association of State Energy Officials (NASEO), plus other states’ energy and energy security agencies
- Local government energy and energy security agencies

## Organization

ESF 12 is organized in accordance with the National Incident Management System (NIMS) and supports the Incident Command Structure (ICS) described in NIMS. ESF 12 actions are, in general, orchestrated by the ESF 12 representative in the SEOC. When appropriate, each ESF 12 Primary and Support entity may establish their own Emergency Operations Center (department or agency EOC) to support ESF activities in consultation and collaboration with the ESF 12 representative in the SEOC. ESF 12 personnel should remain flexible to adapt to the unique conditions of threats and hazards and scale the ESF 12 structure to meet the need of the response.

## Mobilization

Upon SEOC activation, the SEOC Supervisor will contact the ESF 12 representative. The ESF 12 representative will determine if the situation merits the activation of the full team and/or the supporting agencies. Additionally, the ESF 12 representative may request SEOC activation based on an Energy Supply Alert or Energy Emergency.

The Operations Section Chief, in consultation with Operations Section staff and representatives from ESF 1, 2, 3 & 12, may choose to activate an Infrastructure Branch Director to accommodate span of control to provide a streamlined process for critical infrastructure response information.

## Structure

### ESF 12’s Position in the State Emergency Operation’s Center Structure

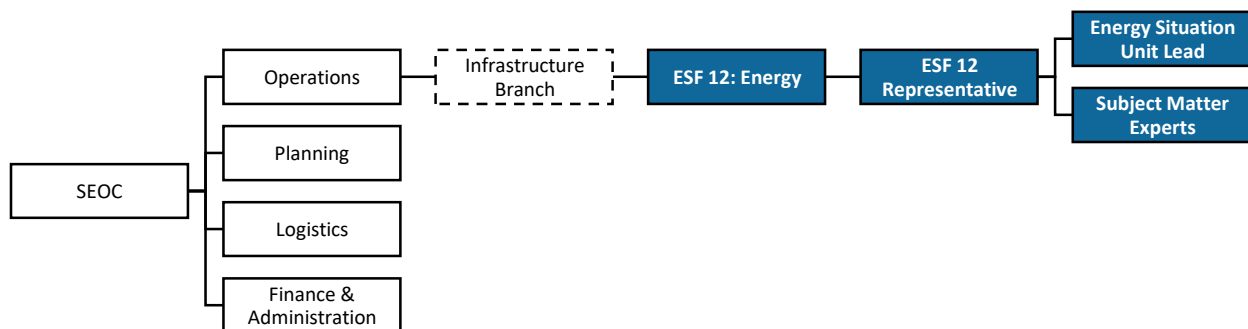

## **Direction, Control & Coordination**

### **Horizontal Integration**

This annex is concerned with the Response Mission Area. It is an interagency plan that provides direction to state government entities concerned with responding to critical infrastructure issues following a disaster.

### **Response**

This annex defines the roles and responsibilities of ESF 12, and compliments similar plans that outline other ESFs within the SEOC. In general, this plan is most likely to be integrated with similar plans for ESF 1, 2 and 3 as part of the Operation Section's Infrastructure Branch; however, it should also be prepared to integrate horizontally with any other state response plan or annex. Integration with state plans during response operations includes:

#### **Washington State Energy Assurance & Emergency Preparedness Plan**

*This plan outlines the processes and options available to address issues relating to scarce electrical and natural gas supply. Some potential options include: waiving regulations to expedite restoration and/or increase efficient use of energy; waiving fuel driver regulations; energy curtailment options; substituting one fuel for another; gasoline station queue management controls; and subsidies for mass transit usage.*

#### **Washington State Fuel Action Plan**

*This plan outlines the processes and options available to address issues relating to scarce petroleum fuel supply including providing public information, reducing fuel demand, acquiring emergency fuel supplies, allocating scarce fuel resources, and mitigating the impacts of scarce fuel resources.*

### **Recovery**

The structures and bodies laid out in this annex should integrate horizontally into structures and bodies established by the Washington Restoration Framework (WRF) to address the Recovery mission area, specifically the Infrastructure Systems Recovery Support Function (RSF). ESF 14 may provide leadership in creating these connections, hosting relevant meetings, and in general ensuring the recovery mission is well coordinated with response.

#### **Infrastructure Systems Recovery Support Function (RSF)**

*This plan describes the organization of Washington State agencies with responsibilities for critical infrastructure recovery under a lead agency. As response efforts transition into a recovery focus, the State Energy Office, and applicable supporting entities, will reorganize as a Recovery Support Function to better align and coordinate program delivery.*

## **Vertical Integration**

This ESF Annex should integrate vertically to federal response plans at the national and regional level, as well as county and city plans at the local level. It may be common for relevant federal and local plans to be similarly titled around ESF 12; however, this annex should remain flexible to coordinate with other plans or bodies that align with the Core Capabilities and Critical Tasks listed in this annex.

### **National Response Framework, ESF 12 Annex**

*This framework presents guiding principles to enable all levels of response partners to provide a unified national response to disasters and emergencies.*

### **National Disaster Recovery Framework, Infrastructure Systems**

*This plan describes the organization of the recovery framework into 6 support functions. The Infrastructure Systems Recovery Support Function coordinates agencies (including Energy) which are responsible for critical infrastructure recovery.*

### **Critical Infrastructure Protection Plan (CIPP)**

*This plan identifies public and private resources that meet the definition and threshold of “critical infrastructure” and identifies vulnerabilities and methodology for prioritizing resources.*

### **Federal Interagency Operational Plan (FIOP)**

*This plan builds upon the National Response Framework by describing the concept of operations for integrating and synchronizing existing Federal capabilities to support local, state, and tribal areas.*

### **National Infrastructure Protection Plan, Energy Sector-Specific Plan**

*This plan outlines how government and private sector participants in the critical infrastructure community work together to manage risks and achieve security and resilience outcomes.*

All 39 counties in Washington State maintain an energy plan. Most integrate their plans under an ESF 12 structure while others may be covered under a different structure such as a Public Utilities District. Most Tribal Nations planning efforts are covered by the county plans, but the Chehalis Tribe, Quinault Tribe, and the Northwest Tribal Emergency Management Council maintain their own Energy-related planning efforts.



Likewise, the following cities maintain their own energy emergency plans which will integrate with the counties' and state's ESF 12 plans: Bellingham, Centralia, Lacey, Olympia, Seattle, Snoqualmie, Tacoma, and Wenatchee.

## Information Collection, Analysis, & Dissemination

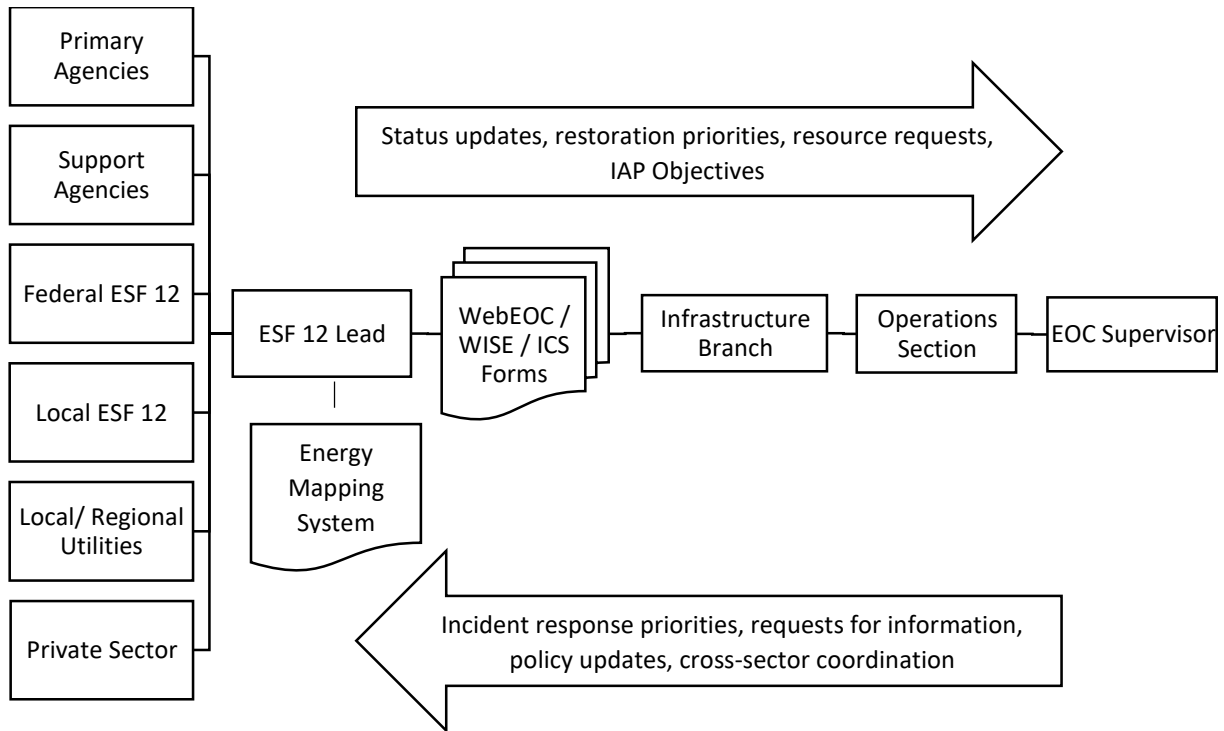

### Information Collection

ESF 12 uses a mapping system to collect and analyze energy information during a response. Specifications for accessing and using this system should be referenced in the ESF 12 Standard Operating Guide.

ESF 12 may additionally use the Department of Energy's mapping system (DOE EAGLE I SYSTEM), the Infrastructure Security and Energy Restoration (ISER) Division website (called ISERNET), and the Department of Homeland Security's Information Network (HSIN) to gather information from our state, federal, and private partners.

The type of information to be collected is first determined by the ESF's Essential Elements of Information (EEI) list below but may be adjusted to fit the needs of the incident.

### **Essential Elements of Information (EEIs)**

Essential Elements of Information (EEIs) are a list of information needs which should guide information collection. This list of EEIs is not exhaustive as the impact of a given disaster may

require unique information collection. Additionally, federal information needs closely align with our own state needs, therefore, the EEI's requested by the Federal Interagency Operational Plan (FIOP), have been integrated with our own list below.

Essential Elements of Information Required for State and Federal Use

<p><b>Disaster impact numbers</b></p>	<ul style="list-style-type: none"> <li>• Number of customers without electricity</li> <li>• Number of customers without natural gas</li> <li>• Number of customers without access to petroleum</li> <li>• Number of energy facilities/systems needing inspection</li> <li>• Status of repair crews; number, type, location</li> <li>• Factors which will limit disaster response or repair</li> </ul>
<p><b>Electricity Generation Facilities</b></p>	<ul style="list-style-type: none"> <li>• Status (operational, damaged, destroyed, unknown)</li> <li>• Approximate restoration date</li> <li>• Limitations or obstacles to restoration</li> </ul>
<p><b>Electricity Transmission Facilities</b></p>	<ul style="list-style-type: none"> <li>• Status (operational, damaged, destroyed, unknown)</li> <li>• Approximate restoration date</li> <li>• Limitations or obstacles to restoration</li> </ul>
<p><b>Electricity Distribution Facilities</b></p>	<ul style="list-style-type: none"> <li>• Status (operational, damaged, destroyed, unknown)</li> <li>• Approximate restoration date</li> <li>• Limitations or obstacles to restoration</li> </ul>
<p><b>Liquefied Natural Gas (LNG) Plants</b></p>	<ul style="list-style-type: none"> <li>• Status (operational, damaged, destroyed, unknown)</li> <li>• Approximate restoration date</li> <li>• Limitations or obstacles to restoration</li> </ul>
<p><b>Natural Gas Processing Facilities</b></p>	<ul style="list-style-type: none"> <li>• Status (operational, damaged, destroyed, unknown)</li> <li>• Approximate restoration date</li> <li>• Limitations or obstacles to restoration</li> </ul>
<p><b>Natural Gas Storage Facilities</b></p>	<ul style="list-style-type: none"> <li>• Status (operational, damaged, destroyed, unknown)</li> <li>• Approximate restoration date</li> <li>• Limitations or obstacles to restoration</li> <li>• Quantity and location of natural gas available</li> </ul>
<p><b>Natural Gas Transportation Systems/Facilities</b></p>	<ul style="list-style-type: none"> <li>• Status (operational, damaged, destroyed, unknown)</li> <li>• Approximate restoration date</li> </ul>

	<ul style="list-style-type: none"> <li>• Limitations or obstacles to restoration</li> </ul>
<b>Natural Gas Distribution Facilities</b>	<ul style="list-style-type: none"> <li>• Status (operational, damaged, destroyed, unknown)</li> <li>• Approximate restoration date</li> <li>• Limitations or obstacles to restoration</li> <li>• Location and status of new and/or temporary fuel distribution points.</li> </ul>
<b>Crude Oil Storage Facilities</b>	<ul style="list-style-type: none"> <li>• Status (operational, damaged, destroyed, unknown)</li> <li>• Approximate restoration date</li> <li>• Limitations or obstacles to restoration</li> <li>• Quantity of crude oil available</li> </ul>
<b>Petroleum Processing Refineries</b>	<ul style="list-style-type: none"> <li>• Status (operational, damaged, destroyed, unknown)</li> <li>• Approximate restoration date</li> <li>• Limitations or obstacles to restoration</li> <li>• Quantity of refined product available</li> </ul>
<b>Petroleum Product Storage</b>	<ul style="list-style-type: none"> <li>• Status (operational, damaged, destroyed, unknown)</li> <li>• Approximate restoration date</li> <li>• Limitations or obstacles to restoration</li> <li>• Quantity and location of refined product available</li> </ul>
<b>Petroleum Product Transportation Systems/Facilities</b>	<ul style="list-style-type: none"> <li>• Status (operational, damaged, destroyed, unknown)</li> <li>• Approximate restoration date</li> <li>• Limitations or obstacles to restoration</li> <li>• Location and status of new and/or temporary fuel distribution points.</li> </ul>
<b>Consumption and Distribution</b>	<ul style="list-style-type: none"> <li>• Consumption rate of natural gas and/or petroleum product.</li> <li>• How much natural gas and/or petroleum product is being requested by emergency response personnel?</li> </ul>
<b>Coal Transportation</b>	<ul style="list-style-type: none"> <li>• Impacts to coal transportation<sup>1</sup></li> </ul>

---

<sup>1</sup> There is one dual natural gas/ coal fired plant in Centralia, Washington owned by TransAlta Corporation. The two coal boilers are scheduled to be decommissioned in 2020 and in 2025; therefore, this plan does not assume that coal will be a major component of response. However, the FIOP requests that we seek out this information if available.

## **Information Analysis**

Using available information, ESF 12 personnel should report location and concentration of customer outages, energy utility facility statuses, and restoration priorities; request resources to aide in restoration; and recommend waivers or other mitigation strategies.

**Restricted Information.** ESF 12 is not allowed to ask about or receive information from utilities about how much petroleum product (refined or crude) or natural gas product is available for use under anti-trust and critical infrastructure protection laws. ESF 12 may gain situational awareness about energy availability from the Utility Transportation Commission (UTC) or from the Energy Information Administration (EIA).

Some information is restricted from dissemination outside of the ESF 12 Team by law. All utility emergency contact information is confidential and should not be made public.

## **Information Dissemination**

Information is to be disseminated to the Operations Section Chief (or Infrastructure Branch Director if activated) using the SEOC incident management software (WebEOC and WISE), or best available system as allowed under the circumstances. In the most austere circumstances, this may be paper ICS forms. ESF 12 entities should especially be familiar with ICS forms 201-206, 213, 214, 230, 233 and the Incident Action Plan (IAP).

## **Responsibilities**

<b>Core Capability</b>	<b>Critical Task I.D.</b>	<b>Activity/Action</b>	<b>Organization(s) Name</b>
<b>Situational Assessment</b>	2	Maintain general data and information on energy systems, including infrastructure location, criticality, capabilities, operations, vulnerabilities and ownership.	State Energy Office
<b>Logistics &amp; Supply Chain Management</b>	2	Maintain state master contracts for petroleum products and propane	Department of Enterprise Services (DES)
<b>Situational Assessment</b>	1	Contact local jurisdictions and utilities to gather situational awareness about the energy sector outages and critical infrastructure status.	State Energy Office
	2		

Core Capability	Critical Task I.D.	Activity/Action	Organization(s) Name
Situational Assessment	2	Contact Western States Petroleum Association to gather situational awareness about the petroleum industry status.	State Energy Office
Situational Assessment	2	Request real-time data on available petroleum and natural gas supply from the Energy Information Administration.	State Energy Office
Situational Assessment	2	Contact British Columbia & Alberta, Canada liaison(s) to gather and share situational awareness about the energy sector status and supply chain	State Energy Office
Situational Assessment	2	Contact Alaska, Oregon Idaho, Montana, Utah liaison(s) to gather and share situational awareness about the energy sector status and supply chain	State Energy Office
Operational Coordination	1	Staff SEOC representative for ESF 12, carrying out actions with a particular emphasis on coordinating stakeholder energy needs and utilities restoration.	State Energy Office
	2		
Situational Assessment	1		
	2		
Operational Coordination	1	Coordinate response and restoration impacting energy sector critical infrastructure with Department of Homeland Security (DHS) CISA Region X	State Energy Office
	2		
Operational Coordination	1	Coordinate response and restoration impacting energy sector critical infrastructure with Department of Energy (DOE)	State Energy Office
	2		
Situational Assessment	1	Collect and analyze EEIs, as categorized by this document and adjusted to fit the need of the incident, to inform the SEOC, facilitate setting utility restoration priorities, relay resource requests, and contribute to the SEOC's incident action plan (IAP).	State Energy Office
	2		
Situational Assessment	1	Map statewide energy sector disruptions of petroleum, electric, and natural gas to support restoration and mitigate supply distribution impacts.	State Energy Office
	2		

Core Capability	Critical Task I.D.	Activity/Action	Organization(s) Name		
Situational Assessment	1	Map statewide and regional energy sector critical infrastructure operational status to support restoration and mitigate supply distribution impacts.	State Energy Office		
	2				
Operational Coordination	1	Consult with local emergency management agencies and service providers to identify areas of prolonged power outage.	State Energy Office		
	2				
Situational Assessment	1				
	2				
Infrastructure Systems	1	Identify energy, utility, and petroleum resources which are in short supply and/or are necessary for the health and safety of the population.	State Energy Office		
	2				
	4				
Operational Coordination	1				
Logistics & Supply Chain Management	2				
Situational Assessment	1				
Infrastructure Systems	4			Consult with energy companies to address critical facilities' restoration priorities, power needs, alternative energy sources, and emergency fuel supplies.	State Energy Office
Operational Coordination	1				
Logistics & Supply Chain Management	2				
Situational Assessment	1				
Infrastructure Systems	2	Recommend state restoration priorities concerning road, rail, ports or other infrastructure facility which will best aid the distribution of power and fuel.	State Energy Office		
	4				
Operational Coordination	2				
Logistics & Supply Chain Management	1				
	2				
Situational Assessment	1				

Core Capability	Critical Task I.D.	Activity/Action	Organization(s) Name
Infrastructure Systems	1	Monitor state agency and statewide petroleum consumption as written in the Washington State Fuel Action Plan.	State Energy Office
Operational Coordination	2		
Logistics & Supply Chain Management	2		
Situational Assessment	2		
Infrastructure Systems	1	Implement waivers and/or programs to reduce demand on petroleum based on the processes written in the Washington State Fuel Action Plan.	State Energy Office
	4		
Operational Coordination	1		
Logistics & Supply Chain Management	2		
Infrastructure Systems	1	Prioritize recipients of limited fuel supplies based on the processes written in the Washington State Fuel Action Plan.	State Energy Office
	4		
Operational Coordination	1		
Logistics & Supply Chain Management	2		
Infrastructure Systems	1	Monitor state agency and statewide electric and natural gas consumption as written in the Washington State Energy Assurance & Emergency Preparedness Plan.	State Energy Office
Operational Coordination	2		
Logistics & Supply Chain Management	2		
Situational Assessment	2		
Infrastructure Systems	1	Allocate scarce energy resources according to the Washington State Energy Assurance & Emergency Preparedness Plan and the Washington State Fuel Action Plan.	State Energy Office
	4		
Operational Coordination	1		
Logistics & Supply Chain Management	2		
	1		

Core Capability	Critical Task I.D.	Activity/Action	Organization(s) Name
Infrastructure Systems	2	Implement waivers to reduce demand on electricity usage and natural gas-based products as written in the Washington State Energy Assurance & Emergency Preparedness Plan.	State Energy Office
	4		
Operational Coordination	1		
Logistics & Supply Chain Management	2		
Infrastructure Systems	1	Implement curtailment recommendations to reduce demand on electricity usage and natural gas-based products as written in the Washington State Energy Assurance & Emergency Preparedness Plan.	State Energy Office
	2		
	4		
Operational Coordination	1		
Logistics & Supply Chain Management	2		
Situational Assessment	1		
		UTC	
Situational Assessment	1	Advise and provide recommendations to the Governor's Office on conditions warranting an Executive Order for an Energy Supply Alert or Energy Emergency.	State Energy Office

**Resource Requirements**

**Micro-level**

ESF 12 needs to be located within the broader SEOC. ESF 12 must have at least four individuals with adequate training to execute the structures and coordination outlined in this annex. Under ideal circumstances, it will have at least two work stations within one of the pods on the SEOC floor, to include all relevant office resources, information/communication technologies, and supporting personnel resources as determined appropriate by the CEMP and SEOC Supervisor.

**Special System Access**

All ESF 12 personnel will need access to WebEOC and the Energy Office's mapping system (previously WAESDTS).

Some ESF 12 personnel may also need preauthorized access to the following systems:



- DOE EAGLE I SYSTEM – Department of Energy Mapping System
- ISERNET - Web site of the Infrastructure Security and Energy Restoration (ISER) Division
- HSIN – Critical Infrastructure Information Network from DHS and FEDs

All ESF 12 personnel should receive the training listed below. Please see the ESF 12 Training Plan for more details.

### **Required Training**

*In person training coordinated through State Energy Office*

- Introduction to ESF 12 Annex & SOP
- Introduction to ESF 12 COOP Plan
- SEOC Foundations (*required for all SEOC personnel*)
- System-Specific Training
  - Energy Office Mapping System (previously WAESDTS) – In person and hands on training
  - WebEOC – In person and hands on training
  - Resource Management (SEOC)

*FEMA online or in-person courses*

- ICS 100, 200, 700, 800 (*required for all SEOC personnel*)
- IS 701.a NIMS Multiagency Coordination System (MACS)
- IS-800.b – National Response Framework – An Introduction
- IS-812 – Emergency Support Function 12 – Energy
- IS-860.c – The National Infrastructure Protection Plan, An Introduction
- IS - 913.a - Critical Infrastructure Security and Resilience: Achieving Results through Partnership and Collaboration
- IS -921.a - Implementing Critical Infrastructure Security and Resilience

It is additionally recommended that ESF 12 personnel receive further training:

### **Recommended Training**

*FEMA online or in-person courses*

- MGT-354: Disaster Management for Electric Power Systems
- E0948: Situational Awareness and Common Operating Picture
- IS-546 – Continuity of Operations Awareness
- IS-120 – An Introduction to Exercises

- IS-230 – Fundamentals of Emergency Management
- IS-235 – Emergency Planning
- IS-546 – Continuity of Operations Awareness
- IS-547 – Introduction to Continuity of Operations
- IS-2001 – Threat and Hazard Identification and Risk Assessment (THIRA)
- IS-2900 – National Disaster Recovery Framework (NDRF) Overview
- PER 280 Strengthening Cooperative Efforts Among Public Safety & Private Sector
- MGT 414 Advanced CI Protection
- MGT 452 Physical & Cybersecurity for Critical Infrastructure and Pipeline Safety

#### *Western Energy Institute*

- Electric Utility Fundamentals and Insights
- Western Energy Institute – Gas Utility Fundamentals and Insights
- Western Energy Institute – Emergency Response and Assistance Practices

### **Macro-level**

ESF 12 requires a reliable method for communicating with ESF 12 stakeholders statewide. This includes communication and information sharing with federal and local ESF 12, local and regional utilities, and relevant private sector organizations. Regular communication and information exchange should also be expected with counterparts in neighboring states. When deploying personnel beyond the SEOC, resources are required to transport personnel and coordination should occur to ensure access to relevant communities and facilities while performing ESF 12 duties as assigned.

## **References and Supporting Guidance**

The following references, links, and guidance are meant to support ESF 12 in the execution of their responsibilities:

### **ESF 12 Standard Operating Guide**

*The ESF 12 Standard Operating Guide (SOG) is a collection of work aids, instructions, reference materials, and contact lists for the ESF 12 Team's use during activation.*

### **ESF 12 Fuel Tracking Tool**

*The ESF 12 Fuel Tracking Tool allows local jurisdictions and agencies to calculate their normal fuel consumption and to estimate their emergency fuel needs.*

## Terms and Definitions

**Critical Infrastructure:** Is defined by the National Infrastructure Protection Plan as “the systems and assets, whether physical or virtual, so vital to the United States that the incapacity or destruction of such systems and assets would have a debilitating impact on security, national economic security, national public health or safety, or any combination of those matters...”

**Curtailment:** the act of reducing or restricting fuel consumption by either voluntary or mandatory means. May be undertaken by utilities or by the State Energy Office.

**Energy Sector:** energy infrastructure which is divided into three interrelated segments: electricity, oil, and natural gas.

**Infrastructure Systems:** the complete supply chain facilities and means for the generation, refinement, transmission, and final delivery to consumers of energy. Includes, but is not limited to: pipelines, substations, transmission lines, and storage facilities.

**Petroleum Fuel:** refers to gasoline and diesel, Jet A/Aviation, and propane.

**Restoration:** defined by utilities as the act of rebuilding infrastructure and reinstating services. Defined by the state as returning the community to a more resilient normal over the long-term.

**Washington Energy Supply Disruption Tracking System (WAESDTS):** Geospatial portal, with corresponding analysis and reporting functions, designed for tracking and managing the effects of disasters on energy infrastructure. Serves as the primary tool for ESF 12 when the WA SEOC is activated.